

RLS Series

• 85°C 3,000Hrs assured.

- Non-solvent proof.
- Long Life.
- For SMPS, Inverter.
- RoHS compliant.
- Halogen-free capacitors are also available.

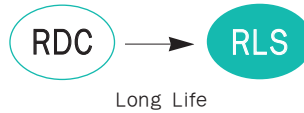

SPECIFICATIONS

Item	Characteristics						
Rated Voltage Range	160 ~ 500 V _{DC}						
Operating Temperature Range	-25 ~ +85°C						
Capacitance Tolerance	±20% (M) (at 20°C, 120Hz)						
Leakage Current	I = 0.02CV or 3mA, whichever is smaller. Where, I: Leakage current(µA) C: Nominal capacitance(µF) V: Rated voltage(V _{DC}) (at 20°C, 5 minutes)						
※ Dissipation Factor(Tanδ)	<table border="1"> <tr> <td>Rated Voltage(V_{DC})</td> <td>160~400</td> <td>450~500</td> </tr> <tr> <td>Tanδ(Max.)</td> <td>0.15</td> <td>0.20</td> </tr> </table> (at 20°C, 120Hz)	Rated Voltage(V _{DC})	160~400	450~500	Tanδ(Max.)	0.15	0.20
Rated Voltage(V _{DC})	160~400	450~500					
Tanδ(Max.)	0.15	0.20					
Temperature Characteristics (Max.Impedance ratio)	<table border="1"> <tr> <td>Rated Voltage(V_{DC})</td> <td>160~400</td> <td>450~500</td> </tr> <tr> <td>Z(-25°C)/Z(20°C)</td> <td>4</td> <td>8</td> </tr> </table> (at 120Hz)	Rated Voltage(V _{DC})	160~400	450~500	Z(-25°C)/Z(20°C)	4	8
Rated Voltage(V _{DC})	160~400	450~500					
Z(-25°C)/Z(20°C)	4	8					
Load Life	<p>The following specifications shall be satisfied when the capacitors are restored to 20°C after the rated voltage is applied for 3,000 hours at 85°C.</p> <p>Capacitance change ≤ ±20% of the initial value Tanδ ≤ 200% of the initial specified value Leakage Current ≤ The initial specified value</p>						
Shelf Life	<p>The following specifications shall be satisfied when the capacitors are restored to 20°C after the exposing them at 85°C. for 1,000 hours without voltage applied. The rated voltage shall be applied to the capacitors for a minimum of 30 minutes, at least 24 hours and not more than 48 hours before the measurement.</p> <p>Capacitance change ≤ ±15% of the initial value Tanδ ≤ 150% of the initial specified value Leakage Current ≤ The initial specified value</p>						
Others	Satisfied characteristics KS C IEC 60384-4						

※ For capacitors with CV products > 100,000 Higher Tanδ value may apply.
 When the capacitance exceeds 1,000µF, 0.01 shall be added every 1,000µF increase.

RATED RIPPLE CURRENT

When capacitors are operated in any other condition at 120Hz, the maximum ripple current must be multiplied by the figure shown in the table.

Frequency multiplying factor

V _{DC} \ Freq.(Hz)	60	120	300	1k	10k~
160~250V _{DC}	0.81	1.00	1.17	1.32	1.45
350~500V _{DC}	0.77	1.00	1.16	1.30	1.41

DIMENSIONS OF RLS Series

Unit(mm)

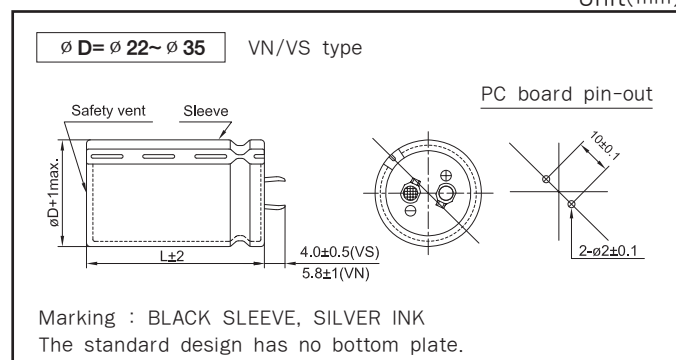

RATINGS OF RLS Series

μF	V _{DC} ∅ D	160				200				250			
		22	25.4	30	35	22	25.4	30	35	22	25.4	30	35
150										22 × 20 0.97			
180										22 × 20 1.06			
220					22 × 20 1.18					22 × 25 1.24	25.4 × 20 1.22		
270	22 × 20 1.30				22 × 20 1.37	25.4 × 20 1.35				22 × 30 1.54	25.4 × 20 1.32		
330	22 × 25 1.50				22 × 25 1.51	25.4 × 20 1.49				22 × 30 1.66	25.4 × 25 1.61	30 × 20 1.58	
390	22 × 25 1.62	25.4 × 20 1.62			22 × 30 1.73	25.4 × 25 1.71	30 × 20 1.71			22 × 35 1.88	25.4 × 30 1.88	30 × 25 1.86	35 × 20 1.71
470	22 × 30 1.86	25.4 × 25 1.86			22 × 30 1.97	25.4 × 25 1.95	30 × 20 1.88				25.4 × 35 2.15	30 × 25 2.05	35 × 20 1.88
560	22 × 30 2.15	25.4 × 25 2.15	30 × 20 2.05		22 × 40 2.18	25.4 × 30 2.15	30 × 25 2.15	35 × 20 2.05			25.4 × 35 2.35	30 × 30 2.36	35 × 25 2.35
680	22 × 35 2.35	25.4 × 30 2.33	30 × 25 2.33	35 × 20 2.26	22 × 40 2.48	25.4 × 30 2.48	30 × 25 2.48	35 × 20 2.36				30 × 30 2.71	35 × 25 2.58
820	22 × 40 2.68	25.4 × 30 2.65	30 × 25 2.64	35 × 20 2.49	22 × 45 2.81	25.4 × 40 2.79	30 × 30 2.80	35 × 25 2.83				30 × 35 2.98	35 × 30 2.88
1,000	22 × 45 3.02	25.4 × 35 3.00	30 × 30 2.96	35 × 25 3.31	22 × 50 3.28	25.4 × 40 3.28	30 × 35 3.15	35 × 30 3.26				30 × 40 3.56	35 × 35 3.48
1,200	22 × 50 3.47	25.4 × 40 3.43	30 × 30 3.41	35 × 25 3.40		25.4 × 45 3.61	30 × 35 3.61	35 × 30 3.57					

μF	V _{DC} ∅ D	350				400				450			
		22	25.4	30	35	22	25.4	30	35	22	25.4	30	35
47										22 × 20 0.54			
56										22 × 20 0.59			
68					22 × 20 0.65					22 × 25 0.71	25.4 × 20 0.68		
82	22 × 20 0.72				22 × 25 0.84	25.4 × 20 0.74				22 × 25 0.86	25.4 × 20 0.74	30 × 20 0.79	
100	22 × 25 0.80				22 × 25 0.99	25.4 × 20 0.82				22 × 30 0.95	25.4 × 25 0.97	30 × 20 0.87	
120	22 × 25 1.04	25.4 × 20 0.90			22 × 30 1.09	25.4 × 25 1.13	30 × 20 0.95			22 × 35 1.07	25.4 × 30 1.09	30 × 25 1.12	35 × 20 0.99
150	22 × 30 1.2	25.4 × 25 1.22	30 × 20 1.06		22 × 35 1.24	25.4 × 30 1.27	30 × 25 1.20			22 × 40 1.18	25.4 × 30 1.25	30 × 25 1.29	35 × 20 1.06
180	22 × 30 1.34	25.4 × 25 1.37	30 × 20 1.16		22 × 40 1.41	25.4 × 30 1.44	30 × 25 1.52	35 × 20 1.16		22 × 45 1.32	25.4 × 35 1.40	30 × 30 1.45	35 × 25 1.33
220	22 × 35 1.47	25.4 × 30 1.53	30 × 25 1.54	35 × 20 1.29	22 × 45 1.58	25.4 × 35 1.64	30 × 30 1.66	35 × 20 1.47		22 × 50 1.48	25.4 × 40 1.59	30 × 30 1.64	35 × 25 1.66
270		25.4 × 35 1.73	30 × 25 1.8	35 × 25 1.49	22 × 50 1.65	25.4 × 40 1.79	30 × 30 1.82	35 × 25 1.63			25.4 × 45 1.73	30 × 35 1.89	35 × 30 1.90
330			30 × 30 2.03	35 × 25 1.80		25.4 × 45 2.00	30 × 35 2.05	35 × 30 2.05			25.4 × 50 2.12	30 × 40 2.12	35 × 35 2.15
390			30 × 35 2.23	35 × 30 2.30		25.4 × 50 2.12	30 × 40 2.26	35 × 35 2.28				30 × 45 2.35	35 × 40 2.38
470			30 × 35 2.53	35 × 30 2.55			30 × 45 2.51	35 × 35 2.54				30 × 50 2.65	35 × 45 2.68
560				35 × 35 2.75			30 × 50 2.85	35 × 40 2.85					35 × 50 2.88
680				35 × 40 3.15	← Case Size ∅ D × L (mm) ← Rated Ripple Current (Arms/85°C, 120Hz)								

RATINGS OF RLS Series

μF	V _{DC} ϕ D	500			
		22	25.4	30	35
56	22 × 35 0.42				
68	22 × 40 0.49	25.4 × 30 0.49			
82	22 × 45 0.57	25.4 × 35 0.58			
100	22 × 50 0.66	25.4 × 40 0.68	30 × 30 0.68		
120		25.4 × 45 0.78	30 × 35 0.79		
150		25.4 × 50 0.92	30 × 40 0.94	35 × 30 0.91	
180			30 × 45 1.08	35 × 35 1.06	
220			30 × 50 1.25	35 × 40 1.23	
270			30 × 60 1.51	35 × 45 1.43	
330				35 × 50 1.66	
390				35 × 60 1.95	

Case Size ϕ D × L (mm) →
 Rated Ripple Current (Arms/85°C, 120Hz) →