

TLJ Series

• 105°C 3,000Hrs assured.

- Non-solvent proof
- High Ripple, Low Temp.
- For SMPS, Inverter.
- RoHS compliant.
- Halogen-free capacitors are also available.

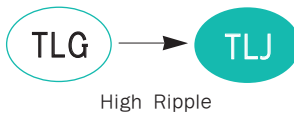

SPECIFICATIONS

Item	Characteristics		
Rated Voltage Range	400 ~ 500 V _{DC}		
Operating Temperature Range	-40 ~ +105°C		
Capacitance Tolerance	±20%(M) (at 20°C, 120Hz)		
Leakage Current	$I = 3\sqrt{CV}$ or 3mA, Whichever is smaller. Where, I: Leakage Current(µA), C: Nominal capacitance(µF), V: Rated voltage(V _{DC}) (at 20°C, 5minutes)		
*Dissipation Factor(Tanδ)	Rated voltage(V _{DC})	400	420 ~ 500
	Tanδ(Max.)	0.15	0.20
Temperature Characteristics (Max. Impedance ratio)	Rated voltage(V _{DC})	400	420 ~ 500
	Z(-25°C)/Z(20°C)	4	8
	Z(-40°C)/Z(20°C)	8	16
	(at 120Hz)		
Load Life	The following specifications shall be satisfied when the capacitors are restored to 20°C after the rated voltage with the rated ripple current is applied (the peak voltage shall not exceed the rated voltage) for 3,000 hours at 105°C Capacitance change ≤ ±20% of the initial value Tanδ ≤ 200% of the initial specified value Leakage current ≤ The initial specified value		
Shelf Life	The following specifications shall be satisfied when the capacitors are restored to 20°C after the exposing them at 105°C for 1,000hours without voltage applied. The rated voltage shall be applied to the capacitors for a minimum of 30 minutes, at least 24 hours and not more than 48 hours before the measurements. Capacitance change ≤ ±20% of the initial value Tanδ ≤ 200% of the initial specified value Leakage current ≤ The initial specified value		
Others	Satisfied characteristics KS C IEC 60384-4		

※For capacitors with CV products >100,000 higher Tanδ value may apply.
 When the capacitance exceeds 1,000µF, 0.01 shall be added every 1,000µF increase.

RATED RIPPLE CURRENT

When capacitor are operated in any other condition at 120Hz, the maximum ripple current must be multiplied by the figure shown in the table.

Frequency multiplying factor

V _{DC}	Freq.(Hz)	60	120	300	1k	10k~
400~500		0.77	1.00	1.16	1.30	1.41

DIMENSIONS OF TLJ Series

Unit(mm)

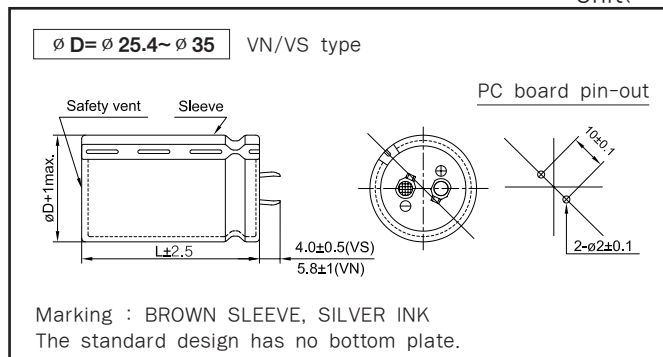

RATINGS OF TLJ Series

V _{DC}	Capacitance (μF)	∅D×L(mm)	Rated Ripple Current (Arms/105°C,120Hz)	V _{DC}	Capacitance (μF)	∅D×L(mm)	Rated Ripple Current (Arms/105°C,120Hz)
400	120	25.4 × 25	1.05	450	100	25.4 × 25	0.92
	180	25.4 × 30	1.34		150	25.4 × 35	1.17
		30 × 25	1.37			30 × 25	1.20
	220	25.4 × 35	1.52		180	25.4 × 40	1.31
	270	25.4 × 40	1.73		220	25.4 × 45	1.50
		30 × 30	1.73			30 × 35	1.50
		35 × 25	1.74			35 × 25	1.51
	330	25.4 × 50	1.98		270	25.4 × 50	1.76
		30 × 35	1.96			30 × 40	1.77
		35 × 30	1.96			35 × 30	1.74
	390	30 × 40	2.21		330	30 × 45	2.02
		35 × 35	2.20			35 × 35	1.99
	470	30 × 50	2.61		390	30 × 50	2.25
		35 × 40	2.58			35 × 40	2.24
560	35 × 45	3.07	470	35 × 45	2.54		
680	35 × 50	3.39	560	35 × 50	2.83		
420	100	25.4 × 25	0.92	500	56	25.4 × 25	0.66
	150	25.4 × 30	1.10		68	25.4 × 25	0.69
		30 × 25	1.20			82	25.4 × 30
	180	25.4 × 35	1.24		100		30 × 25
	220	25.4 × 40	1.43			120	25.4 × 35
		30 × 30	1.43		25.4 × 40		1.11
		35 × 25	1.44		30 × 30		1.12
	270	25.4 × 45	1.69		150	35 × 25	1.14
		30 × 35	1.70			30 × 35	1.26
	330	35 × 30	1.74		180	25.4 × 50	1.45
		30 × 40	1.95			30 × 40	1.47
	390	30 × 45	2.18		220	35 × 30	1.50
		35 × 35	2.17			30 × 45	1.59
	470	30 × 50	2.55		270	35 × 35	1.61
35 × 45		2.54	35 × 40	1.73			
560	35 × 50	2.83	330	35 × 50	1.89		