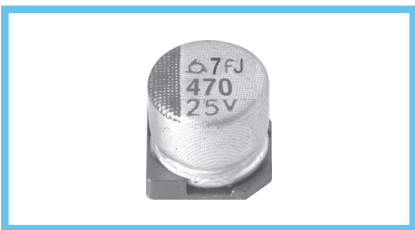

## BXJ Series

• 105°C 2,000~5,000Hrs assured.

- Vertical SMD type.
- Very low Impedance, Long Life.
- For STB, Tuner.
- RoHS compliant.
- Halogen-free capacitors are also available.

Solvent-proof

  
 WV ≤ 63V<sub>DC</sub>

### SPECIFICATIONS

Item	Characteristics																												
Rated Voltage Range	6.3 ~ 50V <sub>DC</sub>	63 ~ 100V <sub>DC</sub>																											
Operating Temperature Range	-55 ~ +105°C	-40 ~ +105°C																											
Capacitance Tolerance	±20%(M) <span style="float: right;">(at 20°C, 120Hz)</span>																												
Leakage Current	I = 0.01CV(μA) or 3μA, whichever is greater. Where, I: Max. Leakage current(μA), C: Nominal capacitance(μF), V: Rated voltage(V <sub>DC</sub> ) <span style="float: right;">(at 20°C, 2 minutes)</span>																												
Dissipation Factor (Tanδ)	<table border="1" style="width: 100%; border-collapse: collapse; text-align: center;"> <tr> <td style="font-size: small;">Rated Voltage(V<sub>DC</sub>)</td> <td>6.3</td><td>10</td><td>16</td><td>25</td><td>35</td><td>50</td><td>63</td><td>100</td> </tr> <tr> <td style="font-size: small;">Tanδ (Max.)</td> <td>0.26</td><td>0.19</td><td>0.16</td><td>0.14</td><td>0.12</td><td>0.12</td><td>0.12</td><td>0.12</td> </tr> </table> <span style="float: right;">(at 20°C, 120Hz)</span>		Rated Voltage(V <sub>DC</sub> )	6.3	10	16	25	35	50	63	100	Tanδ (Max.)	0.26	0.19	0.16	0.14	0.12	0.12	0.12	0.12									
Rated Voltage(V <sub>DC</sub> )	6.3	10	16	25	35	50	63	100																					
Tanδ (Max.)	0.26	0.19	0.16	0.14	0.12	0.12	0.12	0.12																					
Temperature Characteristics (Max. Impedance ratio)	<table border="1" style="width: 100%; border-collapse: collapse; text-align: center;"> <tr> <td style="font-size: small;">Rated voltage(V<sub>DC</sub>)</td> <td>6.3</td><td>10</td><td>16</td><td>25</td><td>35</td><td>50</td><td>63</td><td>100</td> </tr> <tr> <td style="font-size: small;">Z(-25°C)/Z(+20°C)</td> <td>3</td><td>2</td><td>2</td><td>2</td><td>2</td><td>2</td><td>3</td><td>3</td> </tr> <tr> <td style="font-size: small;">Z(-55°C)/Z(+20°C)</td> <td>5</td><td>4</td><td>4</td><td>3</td><td>3</td><td>3</td><td>※4</td><td>※4</td> </tr> </table> <span style="float: right;">※Z(-40°C)/Z(+20°C) (at 120Hz)</span>		Rated voltage(V <sub>DC</sub> )	6.3	10	16	25	35	50	63	100	Z(-25°C)/Z(+20°C)	3	2	2	2	2	2	3	3	Z(-55°C)/Z(+20°C)	5	4	4	3	3	3	※4	※4
Rated voltage(V <sub>DC</sub> )	6.3	10	16	25	35	50	63	100																					
Z(-25°C)/Z(+20°C)	3	2	2	2	2	2	3	3																					
Z(-55°C)/Z(+20°C)	5	4	4	3	3	3	※4	※4																					
Load Life	The following specifications shall be satisfied when the capacitors are restored to 20°C after the rated voltage is applied with the following conditions. D56~H63, J85 : 105°C, 2,000 hours, H10 ~ K14 : 105°C, 5,000 hours.  Capacitance change D56~H63, J85    ≤ ±30% of the initial value H10~K14        ≤ ±35% of the initial value  Tanδ                ≤ 300% of the initial specified value  Leakage current    ≤ The initial specified value																												
Shelf Life	The following specifications shall be satisfied when the capacitors are restored to 20°C after exposing them for 1,000 hours at 105°C without voltage applied. The rated voltage shall be applied to the capacitors for a minimum of 30 minutes, at least 24 hours and not more than 48 hours before the measurements.  Capacitance change D56~H63, J85    ≤ ±30% of the initial value H10~K14        ≤ ±35% of the initial value  Tanδ                ≤ 300% of the initial specified value  Leakage current    ≤ The initial specified value																												
Others	Satisfied characteristics KS C IEC 60384-4																												

## BXJ Series

### PART NUMBERING SYSTEM

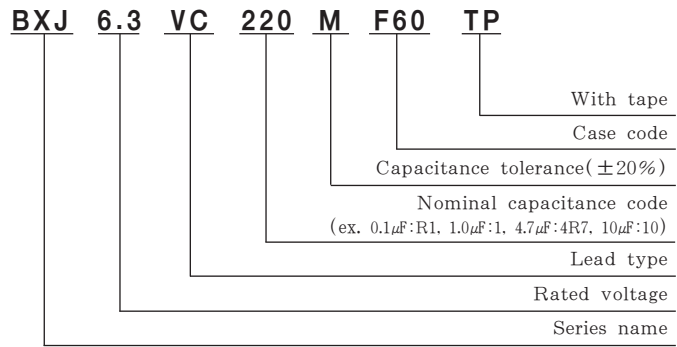

### RATED RIPPLE CURRENT MULTIPLIERS

Frequency Multipliers

Size code	Cap.(μF)	Freq.(Hz)			
		120	1K	10K	100K
D56 ~ J10	4.7	0.35	0.70	0.90	1.00
	10 ~ 100	0.40	0.75	0.90	1.00
	220 ~ 470	0.50	0.85	0.94	1.00
	1,000 ~ 1,500	0.60	0.87	0.95	1.00
K14	47 ~ 100	0.40	0.75	0.90	1.00
	330 ~ 470	0.50	0.85	0.94	1.00
	680 ~ 2,000	0.60	0.87	0.95	1.00



# SURFACE MOUNT ALUMINUM ELECTROLYTIC CAPACITORS

## DIMENSIONS OF BXJ Series

Unit(mm)

### DIMENSIONS

● Vibration Resistance

<Size code: D56~K14>    <Size code: H10~K14>

: Dummy terminals  
**Recommended solder land on PC board**

: Solder land on PC board

### MARKING

Note 1 : L±0.5 for 8×6.3(H63)~12.5×13.5(K14)  
 Note 2 : 4×5.3(D56), 4×5.8(D61), 5×5.3(E56), 5×5.8(D61) is excluded symbol mark.  
 Note 3 : 6.3WV is marked by 6V.

Case code	φD	L	A	B	C	W	P	a	b	c	a	b	c
D56	4	5.3	4.3	4.3	5.1	0.5-0.8	1.0	1.0	2.6	1.6			
D61	4	5.8	4.3	4.3	5.1	0.5-0.8	1.0	1.0	2.6	1.6			
E56	5	5.3	5.3	5.3	5.9	0.5-0.8	1.4	1.4	3.0	1.6			
E61	5	5.8	5.3	5.3	5.9	0.5-0.8	1.4	1.4	3.0	1.6			
F55	6.3	5.2	6.6	6.6	7.2	0.5-0.8	1.9	1.9	3.5	1.6			
F60	6.3	5.7	6.6	6.6	7.2	0.5-0.8	1.9	1.9	3.5	1.6			
F80	6.3	7.7	6.6	6.6	7.2	0.5-0.8	1.9	1.9	3.5	1.6			
H63	8	6.3	8.3	8.3	9.0	0.5-0.8	2.3	2.3	4.5	1.6			
H10	8	10	8.3	8.3	9.0	0.7-1.1	3.1	3.1	4.2	2.2	3.1	4.2	3.5
J85	10	8.5	10.3	10.3	11.0	0.7-1.1	4.5	4.5	4.4	2.2			
J10	10	10	10.3	10.3	11.0	0.7-1.1	4.5	4.5	4.4	2.2	4.5	4.4	3.5
K14	12.5	13.5	13.0	13.0	13.7	1.0-1.3	4.2	4.0	5.7	2.5	3.4	6.3	9.3

● Vibration Resistance ↑

## RATINGS OF BXJ Series

μF	V <sub>dc</sub>																													
	6.3			10			16			25			35			50			63			100								
4.7													D56	1.80	85	D61	5.50	45												
																E56	3.00	55												
10							D56	1.80	85	D56	1.80	85	D56	1.80	85	E61	2.00	50	F60	4.50	48	H63	1.80	85	J85	1.35	100			
22				D56	1.80	85	E56	0.80	155	E56	0.80	155	E61	0.70	160	F60	1.20	120	H63	1.50	100	H10	1.50	160						
33	D56	1.80	85	D61	1.35	90	F60	0.36	240	F60	0.36	240	F60	0.36	240	F80	0.90	150	J85	0.95	205	J10	0.60	330						
47	D61	1.35	90	E61	0.70	160	F60	0.36	240	F60	0.36	240	F60	0.36	240	H63	0.75	200	H10	1.00	200	K14	0.40	400						
	E56	0.80	155	F60	0.36	240																								
68	E61	0.70	160	E61	0.70	160	F60	0.36	240	F60	0.36	240	F80	0.34	280	H10	0.44	300	J10	0.50	350	K14	0.40	400						
	F60	0.36	240	F60	0.36	240																								
100	E61	0.70	160	F60	0.36	240	F60	0.36	240	H63	0.26	300	H10	0.16	600	H10	0.44	300	J10	0.50	350	K14	0.40	400						
	F60	0.36	240																											
220	F60	0.36	240	F80	0.34	280	F80	0.34	280	J85	0.15	620	H10	0.16	600	J85	0.40	315	J10	0.25	500									
330	F80	0.34	280	H10	0.16	600	J85	0.15	620	J10	0.08	850	H10	0.16	600	J10	0.25	500												
470	H10	0.16	600	H10	0.16	600	J10	0.08	850	J10	0.08	850	J10	0.08	850	K14	0.11	650												
	J85	0.15	620	J85	0.15	620																								
1,000	H10	0.16	600	J10	0.08	850	K14	0.06	1,100	K14	0.06	1,100																		
1,500	J10	0.08	850	K14	0.06	1,100																								
2,200	K14	0.06	1,100	K14	0.06	1,100																								

↑ Rated Ripple Current (mA rms/105°C, 100kHz)  
 ↑ Impedance (Ω max./20°C, 100kHz)  
 ↑ Case code