

TLA Series

• 105°C 3,000Hrs assured.

- Non-solvent proof.
- Long Life.
- Equal to TDA case size
- For SMPS, Inverter
- RoHS compliant.
- Halogen-free capacitors are also available.



SPECIFICATIONS

Item	Characteristics						
Rated Voltage Range	160 ~ 450 V _{bc}						
Operating Temperature Range	-25 ~ +105°C						
Capacitance Tolerance	±20%(M) (at 20°C, 120Hz)						
Leakage Current	I = 0.02CV or 3mA, whichever is smaller. Where, I: Leakage Current(µA), C: Nominal capacitance(µF), V: Rated voltage(V _{bc}) (at 20°C, 5minutes)						
※ Dissipation Factor(Tan δ)	<table border="1"> <tr> <td>Rated voltage(V_{bc})</td> <td>160 ~ 450</td> </tr> <tr> <td>Tan δ(Max.)</td> <td>0.20</td> </tr> </table> (at 20°C, 120Hz)	Rated voltage(V _{bc})	160 ~ 450	Tan δ(Max.)	0.20		
Rated voltage(V _{bc})	160 ~ 450						
Tan δ(Max.)	0.20						
Temperature Characteristics (Max. Impedance ratio)	<table border="1"> <tr> <td>Rated voltage(V_{bc})</td> <td>160 ~ 400</td> <td>420 ~ 450</td> </tr> <tr> <td>Z(-25°C)/Z(20°C)</td> <td>4</td> <td>8</td> </tr> </table> (at 120Hz)	Rated voltage(V _{bc})	160 ~ 400	420 ~ 450	Z(-25°C)/Z(20°C)	4	8
Rated voltage(V _{bc})	160 ~ 400	420 ~ 450					
Z(-25°C)/Z(20°C)	4	8					
Load Life	The following specifications shall be satisfied when the capacitors are restored to 20°C after the rated voltage is applied for 3,000 hours at 105°C. Capacitance change ≤ ±20% of the initial value Tan δ ≤ 200% of the initial specified value Leakage current ≤ The initial specified value						
Shelf Life	The following specifications shall be satisfied when the capacitors are restored to 20°C after the exposing them at max. operating temperature for 1,000 hours without voltage applied. The rated voltage shall be applied to the capacitors for a minimum of 30 minutes, at least 24 hours and not more than 48 hours before the measurements. Capacitance change ≤ ±20% of the initial value Tan δ ≤ 200% of the initial specified value Leakage current ≤ The initial specified value						
Others	Satisfied characteristics KS C IEC 60384-4						

※For capacitors with CV products >100,000 higher Tan δ value may apply.
 When the capacitance exceeds 1,000µF, 0.01 shall be added every 1,000µF increase.

RATED RIPPLE CURRENT

When capacitor are operated in any other condition at 120Hz, the maximum ripple current must be multiplied by the figure shown in the table.

Frequency multiplying factor

Frequency(Hz)	60	120	300	1k	10k~
160~250V _{bc}	0.81	1.00	1.17	1.32	1.45
350~450V _{bc}	0.77	1.00	1.16	1.30	1.41

DIMENSIONS OF TLA Series

Unit (mm)

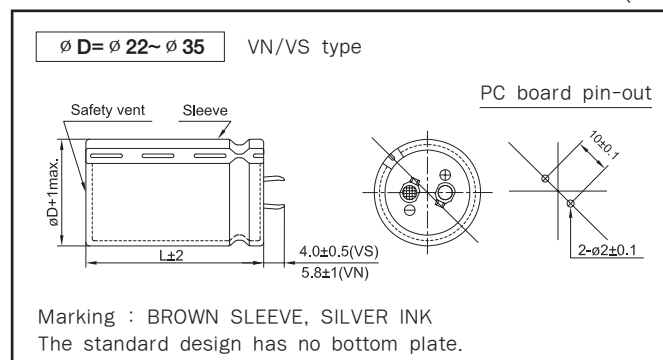



LARGE SIZED ALUMINUM ELECTROLYTIC CAPACITORS

RATINGS OF TLA Series

Vdc μF / ϕD	160				200				250			
	22	25.4	30	35	22	25.4	30	35	22	25.4	30	35
180									22 × 25 0.78			
220									22 × 25 1.00	25.4 × 25 0.95		
270					22 × 25 1.10				22 × 30 1.18	25.4 × 25 1.18		
330	22 × 25 1.20				22 × 30 1.25	25.4 × 25 1.25			22 × 35 1.30	25.4 × 35 1.30	30 × 25 1.30	
390	22 × 25 1.30	25.4 × 25 1.26			22 × 30 1.35	25.4 × 25 1.35			22 × 40 1.49	25.4 × 35 1.49	30 × 25 1.49	
470	22 × 30 1.55	25.4 × 25 1.55			22 × 40 1.67	25.4 × 30 1.50	30 × 25 1.50		22 × 45 1.65	25.4 × 35 1.65	30 × 30 1.65	35 × 25 1.65
560	22 × 35 1.67	25.4 × 30 1.67	30 × 25 1.67		22 × 45 1.67	25.4 × 30 1.67	30 × 25 1.67		22 × 50 1.67	25.4 × 40 1.80	30 × 30 1.80	35 × 25 1.80
680	22 × 40 1.82	25.4 × 30 1.82	30 × 25 1.82		22 × 45 1.78	25.4 × 35 1.78	30 × 30 1.78	35 × 25 1.78		25.4 × 50 2.00	30 × 35 2.00	35 × 30 2.00
820	22 × 45 2.04	25.4 × 35 2.04	30 × 30 2.04	35 × 25 2.04		25.4 × 45 2.04	30 × 30 2.04	35 × 25 2.04		25.4 × 60 2.20	30 × 40 2.30	35 × 35 2.30
1,000	22 × 50 2.25	25.4 × 40 2.25	30 × 30 2.25	35 × 25 2.25		25.4 × 50 2.30	30 × 35 2.30	35 × 30 2.30			30 × 50 2.47	35 × 40 2.47
1,200		25.4 × 45 2.49	30 × 35 2.49	35 × 30 2.49		25.4 × 60 2.66	30 × 40 2.65	35 × 35 2.65			30 × 60 2.85	35 × 45 2.60
1,500		25.4 × 60 2.97	30 × 40 2.84	35 × 30 2.84			30 × 50 3.08	35 × 40 3.08				35 × 50 3.00
1,800			30 × 45 3.32	35 × 35 3.00			30 × 60 3.49	35 × 45 3.48				35 × 60 3.42
2,200			30 × 60 3.86	35 × 45 3.50				35 × 50 3.78	← Case Size ϕD × L (mm) ← Rated Ripple Current (Arms/105°C, 120Hz)			

Vdc μF / ϕD	350				400			
	22	25.4	30	35	22	25.4	30	35
56								
68					22 × 25 0.55			
82	22 × 25 0.55				22 × 25 0.64			
100	22 × 25 0.69				22 × 30 0.70	25.4 × 25 0.70		
120	22 × 30 0.75	25.4 × 25 0.75			22 × 35 0.75	25.4 × 25 0.75	30 × 25 0.80	
150	22 × 35 0.82	25.4 × 30 0.83	30 × 25 0.82		22 × 40 0.88	25.4 × 30 0.88	30 × 25 0.88	
180	22 × 40 0.92	25.4 × 30 0.92	30 × 25 0.90		22 × 45 0.98	25.4 × 35 0.98	30 × 30 0.98	35 × 25 0.98
220	22 × 45 1.05	25.4 × 35 1.04	30 × 30 1.02	35 × 25 1.04	22 × 50 1.10	25.4 × 40 1.10	30 × 30 1.10	35 × 25 1.0
270	22 × 50 1.16	25.4 × 40 1.18	30 × 30 1.17	35 × 25 1.20		25.4 × 45 1.22	30 × 35 1.22	35 × 30 1.22
330		25.4 × 45 1.29	30 × 35 1.34	35 × 30 1.22		25.4 × 50 1.44	30 × 40 1.44	35 × 30 1.44
390		25.4 × 50 1.51	30 × 40 1.51	35 × 35 1.47		25.4 × 60 1.51	30 × 45 1.60	35 × 35 1.60
470		25.4 × 60 1.66	30 × 45 1.65	35 × 35 1.69			30 × 50 1.90	35 × 40 1.90
560			30 × 50 1.85	35 × 40 1.90			30 × 60 2.10	35 × 45 2.12
680			30 × 60 2.15	35 × 50 1.99				35 × 60 2.27

RATINGS OF TLA Series

μF	V _{DC} ϕD	420				450			
		22	25.4	30	35	22	25.4	30	35
56						22 × 25 0.40			
68		22 × 25 0.50				22 × 30 0.53	25.4 × 25 0.50		
82		22 × 25 0.64	25.4 × 25 0.58			22 × 30 0.64	25.4 × 25 0.64		
100		22 × 30 0.70	25.4 × 25 0.70			22 × 35 0.69	25.4 × 30 0.69	30 × 25 0.64	
120		22 × 35 0.75	25.4 × 30 0.75	30 × 25 0.73		22 × 40 0.80	25.4 × 30 0.80	30 × 25 0.80	35 × 25 0.73
150		22 × 40 0.88	25.4 × 35 0.88	30 × 25 0.88		22 × 45 0.88	25.4 × 35 0.88	30 × 30 0.88	35 × 25 0.75
180		22 × 45 0.95	25.4 × 35 0.95	30 × 30 0.95	35 × 25 0.94	22 × 50 1.00	25.4 × 40 1.00	30 × 30 1.00	
220		22 × 50 1.10	25.4 × 45 1.10	30 × 35 1.10	35 × 25 1.10		25.4 × 45 1.12	30 × 35 1.12	35 × 30 1.12
270			25.4 × 50 1.22	30 × 40 1.22	35 × 30 1.22		25.4 × 50 1.18	30 × 40 1.28	35 × 35 1.28
330			25.4 × 60 1.41	30 × 45 1.45	35 × 35 1.45			30 × 50 1.45	35 × 40 1.45
390				30 × 50 1.55	35 × 40 1.55			30 × 60 1.51	35 × 40 1.55
470				30 × 60 1.79	35 × 45 1.90	← Case Size $\phi\text{D} \times \text{L}$ (mm) ← Rated Ripple Current (Arms/105°C, 120Hz)			35 × 50 1.85